

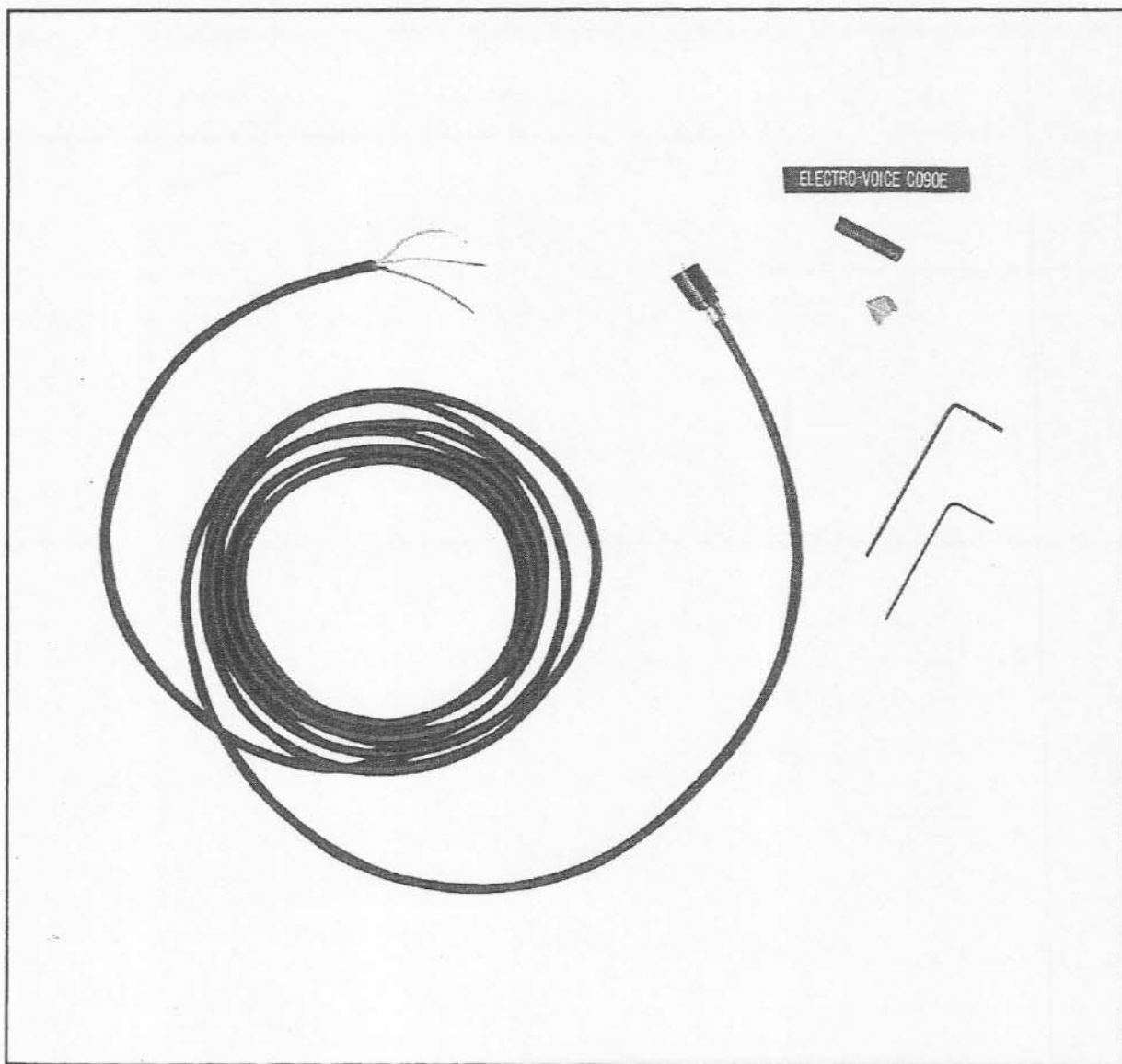

# Electro-Voice® MICROPHONE REPAIR KITS

## OWNER'S MANUAL



**CO10R Cable Repair Kit**

**DESCRIPTION:**

The CO10R is a cable repair kit for the CO90, CO90E, CO94, CO100, CO100E, CS200, CS200E, PL4, RE98, CP212, and CP218 microphones. The CO10R replaces the CO9R Repair Kit.

The majority of problems encountered with lapel or gooseneck type microphones are a result of a worn and damaged cable. The CO10R Repair Kit contains a 10 foot replacement electronic cable, a banding clamp (for the CO90), heat shrink tubing 1.5 inches long (for the CO100 and CS200) and .63 inches long (for the CP212 and CP218), a .035 and .050 hex-key wrench, and detailed instructions for replacing the damaged electronic cable assembly on any of the above mentioned microphones. To customize your microphone's cable length, instructions for preparing the cable end is included for each model. For CO90E, CO100E and CS200E owners, wiring diagrams for installation on wireless transmitters are provided. Other replacement parts for these microphones may be ordered from Electro-Voice.

The CO10R Repair Kit has been provided for the convenience of field repair; however if you feel that the cable replacement is beyond your capability or the microphone still does not operate after cable replacement, authorized factory repair service may be obtained by returning the microphone to:

Electro-Voice, Inc.,  
Attn: Service/Repair Department  
600 Cecil Street  
Buchanan, Michigan 49107

PH: 616-695-6831

Toll Free: 800-685-2606

OR

Electro-Voice West  
8234 Doe Avenue  
Visalia, CA 93291

FAX: 209-651-0164

PHONE: 209-651-7777

**CO10R REPAIR KIT PARTS LIST**  
(PART NUMBER 82799):

Item	Description	Part No.	Required
1	Electronics and cable assembly	82764	1
2	Banding clamp	20247	1
3	Instruction sheet	531958	1
4	0.035-in. Hex key wrench	20531	1
5	0.050-in. Hex key wrench	20542	1
6	Heat-shrink tubing, 1.5-in. long	F66051	1
7	Heat-shrink tubing, 0.63-in. long	B66013	1

**TOOLS REQUIRED:**

The tools suggested for replacing the electronic cable are the hand tools normally found at any electronics work station.

- Low wattage soldering iron, approximately 25 watts
- Electronic-grade solder with resin core flux
- .035 hex-key wrench (supplied with CO10R)
- .050 hex-key wrench (supplied with CO10R)
- Small wire cutters
- Wire strippers
- Small needle-nosed pliers or tweezers
- Crimping or regular gas pliers (for the CO90/CO90E)
- Razor blade or very sharp knife
- Number 2 (medium) crossed-recessed screwdriver (for the RE98)
- Small ruler
- Small vise
- Heat gun or other heat source (for the CP212, and CP218, optional for the CO100 and CS200)

**CO90/CO90E INSTRUCTIONS:**

1. Disassemble the CO90 microphone to be repaired as follows (refer to Figure 1):
  - a. Remove the head capsule (Item 1) by unscrewing it from the electronics housing (Item 3).
  - b. Remove the battery transformer housing and belt clip (Items 12 and 13) by unscrewing them from Item 5.
2. Cut the miniature microphone cable anywhere between Item 3 and Item 5.
3. Loosen the set screw (Item 4) in the electronics housing with the provided .035 hex-key wrench by turning the set screw counterclockwise several turns.
4. Push the cable on Item 2 towards Item 3 and remove Item 2 completely from Item 3. You may discard the old Item 2.
5. Thread the cable end of replacement Item 2 through the hole in Item 3. Pull on the cable until the electronics assembly is seated in Item 3. Tighten set screw (Item 4) until snug and Item 2 is retained in Item 3. Screw the head capsule (Item 1) onto the electronics housing (Item 3). (NOTE: This completes the repair of the CO90E.)
6. On Item 5, remove set screw (Item 6) with the provided .050 hex-key wrench. Push the cable towards the metal shell (Item 5) until the plastic inserts (Item 7) are free from Item 5.
7. Item 7 can now be separated, exposing the contact assembly (Items 9, 10, and 11) and the banding clamp (Item 8).
8. Unsolder the red wire and capacitor lead from the contact assembly (Items 9, 10, and 11).
9. Remove the capacitor from the banding clamp by opening the band and removing the capacitor's lead wire.

**NOTE:** Refer to Figure 2 for the following steps.

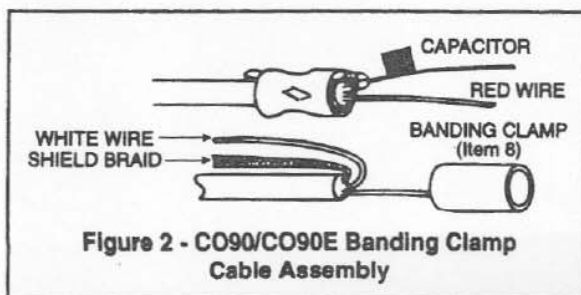

**Figure 2 - CO90/CO90E Banding Clamp Cable Assembly**

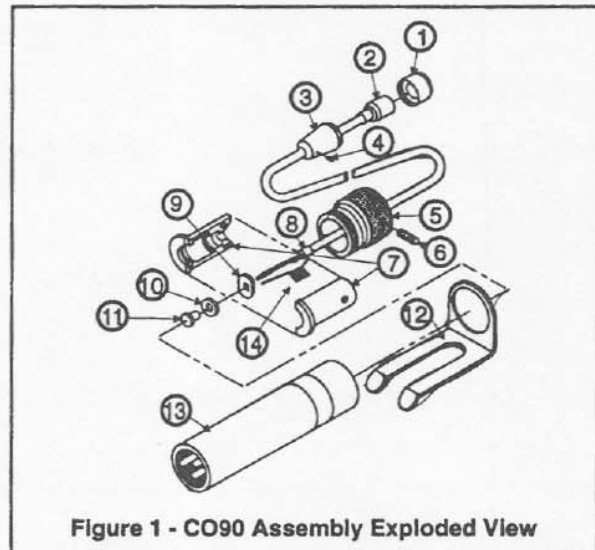

**Figure 1 - CO90 Assembly Exploded View**

**NOTE:** Stripping of the delicate inner conductor insulation is best accomplished with wire strippers or with the tip of a hot soldering iron.

10. Measure and carefully remove one inch (25.4 mm) of the black outer jacket insulation from the end of the cable.
11. Carefully remove the white and red wires from the inside of the braided shield. This can be done by bending the braid at the jacket with tweezers or needle nosed pliers by gently separating the braid at the bend then pull and remove the wires. Remove and cut off all cotton threads encased in the shield braid.
12. Measure and remove .25 inch (6.3 mm) of insulation from the red wire.
13. Remove all exposed insulation from the white wire.
14. Making certain the white wire on the new replacement cable assembly (Item 2) is stripped completely of insulation, twist the shield braid and the white wire together and fold them back onto the microphone cable.
15. Carefully position the new banding clamp (Item 8) over the end of the cable and squeeze it with a pair of pliers to capture the shield, the white wire, and the capacitor lead. Trim the excess wire from the banding clamp.
16. Solder the red wire and the capacitor lead to the contact assembly (Items 9, 10, and 11).
17. Assemble the repaired microphone by reversing Steps 7 and 6.

**CO94 AND PL4 INSTRUCTIONS:**

1. Disassemble the CO94/PL4 microphone to be repaired as follows: (refer to Figure 3)
  - a. Remove the head capsule (Item 1) by unscrewing it from the electronics housing (Item 2).
  - b. Remove the electronics and cable assembly (Item 4) from the battery/electronics housing (Item 6) by disconnecting the mini three-pin XLR connector (Item 5).
2. Cut the miniature microphone cable anywhere between Item 2 and Item 5.
3. Loosen the set screw (Item 3) in the electronics housing with the provided .035 hex-key wrench by turning the set screw counterclockwise several turns.
4. Push the cable on Item 4 towards Item 2 and remove Item 4 completely from Item 2. You may discard the old Item 4.
5. Thread the cable end of replacement Item 4 through the hole in Item 2. Pull on the cable until the electronics assembly is seated in Item 2. Tighten the set screw (Item 3) until it is snug and Item 4 is retained in Item 2. Screw the head capsule (Item 1) onto the electronics housing (Item 2).

**NOTE:** Refer to Figure 4 for the following steps.

**NOTE:** Stripping of the delicate inner conductor insulation is best accomplished with wire strippers or with the tip of a hot soldering iron.

6. Measure and carefully remove .5 inch (12.7 mm) of the black outer jacket insulation from the end of the cable.
7. Carefully remove the white and red wires from the inside of the braided shield. This can be done by bending the braid at the jacket and with tweezers or needle nosed pliers by gently separating the braid at the bend then pull and remove the wires. Remove and cut off all cotton threads encased in the shield braid.
8. Measure and remove .25 inch (6.3 mm) of insulation from the red and white wires.
9. Unscrew the plastic shell and flex relief from the mini three-pin XLR connector; thread the end of the cable through the shell/flex relief.

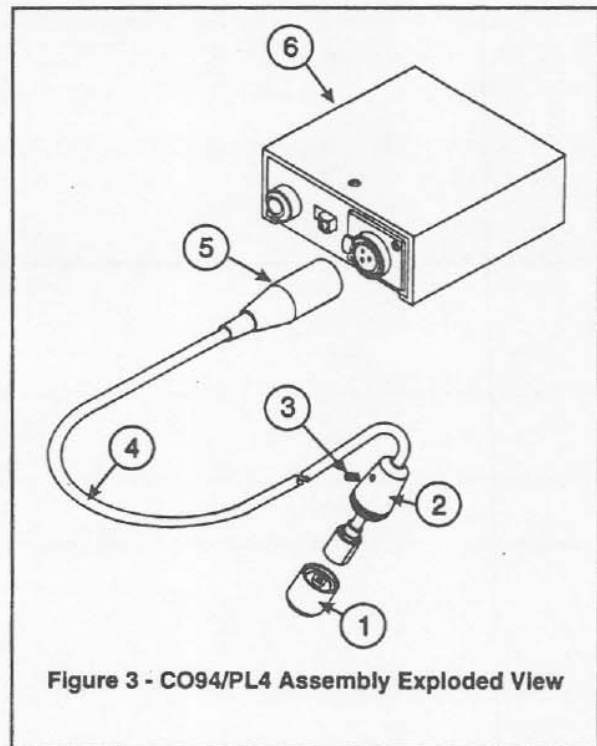

Figure 3 - CO94/PL4 Assembly Exploded View

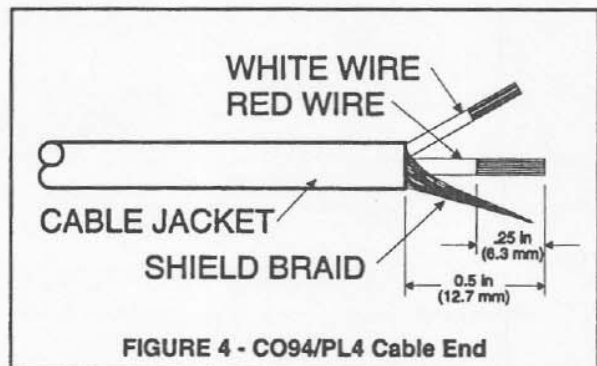

FIGURE 4 - CO94/PL4 Cable End

10. Pry away from the cable jacket the four tongs of the strain relief with the needle nosed pliers. Thread the end of the cable through the strain relief.
11. Remove insulation sleeve and thread the end of the cable through the sleeve.
12. Secure the three-pin-connector (this is where a vise comes in handy) and with the hot soldering iron remove the damaged cable wires from the connector pins.



**NOTE:** Refer to Figure 5 for the following steps.

13. Carefully, solder the red wire to pin 3; the white wire to pin 2; the shield braid to pin 1. Inspect for loose wires or solder bridges between the pins.
14. Reverse steps 9 through 11 to reassemble the mini three-pin XLR connector.
15. Assemble the repaired microphone by connecting the microphone assembly to the battery/electronics housing.

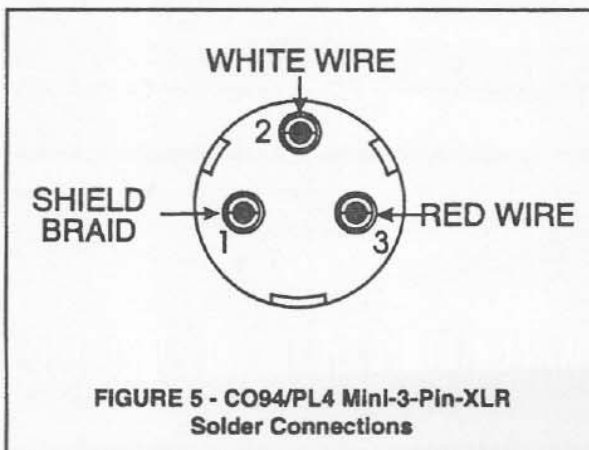

**FIGURE 5 - CO94/PL4 Mini-3-Pin-XLR Solder Connections**

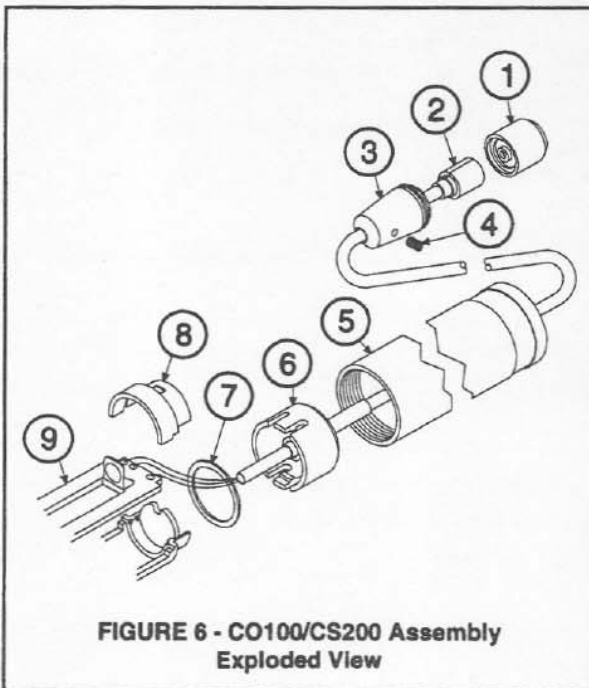

**FIGURE 6 - CO100/CS200 Assembly Exploded View**

### CO100/CS200 AND CO100E/CS200E INSTRUCTIONS:

1. Disassemble the CO100/CS200 microphone to be repaired as follows: (refer to Figure 6)
  - a. Remove the head capsule (Item 1) by unscrewing it from the electronics housing (Item 3).
  - b. Cut the miniature microphone cable anywhere between Item 3 and Item 5.
2. Loosen the set screw (Item 4) in the electronics housing with the provided .035 hex-key wrench by turning the set screw counterclockwise several turns.
3. Push the cable on Item 2 towards Item 3 and remove Item 2 completely from Item 3. You may discard the old Item 2.
4. Thread the cable end of replacement Item 2 through the hole in Item 3. Pull on the cable until the electronics assembly is seated in Item 3. Tighten set screw (Item 4) until snug and Item 2 is retained in Item 3. Screw the head capsule (Item 1) onto the electronics housing (Item 3). (Note: this completes the repair of the CO100E/CS200E.)

**NOTE:** Stripping of the delicate inner conductor insulation is best accomplished with wire strippers or with the tip of a hot soldering iron. (Refer to Figure 4).

5. Measure and carefully remove .5 inch (12.7 mm) of the black outer jacket insulation from the end of the cable.
6. Carefully remove the white and red wires from the inside of the braided shield. This can be done by bending the braid at the jacket and with tweezers or needle nosed pliers by gently separating the braid at the bend then pull and remove the wires. Remove and cut off all cotton threads encased in the shield braid.
7. Measure and remove .25 inch (6.3 mm) of insulation from the red and white wires.

Step 8 is the optional addition of the heat shrink, flex relief tubing. The microphone will electrically and acoustically operate normally without the addition of the heat shrink flex relief if a directed, controlled heat source of 275 degrees F (135 degrees C), such as a heat gun, is not available. The hot tip of a soldering iron can substitute for a heat gun but care must be taken not to melt the shrink tubing or the cable jacket.

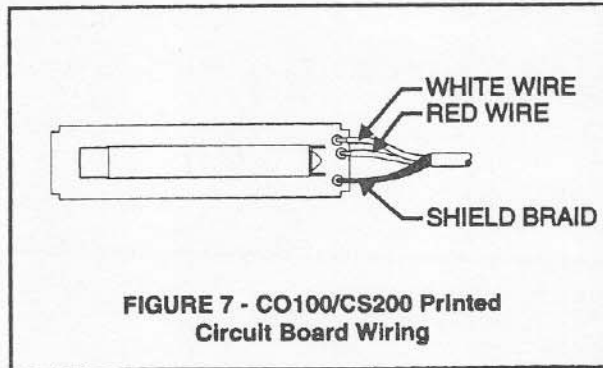

**FIGURE 7 - CO100/CS200 Printed Circuit Board Wiring**

8. Insert the wire end of the cable through the heat shrink tubing. Position the end of the tubing .5 inches (12.7 mm) from the end of the black insulating jacket. Using a heat gun set for 275 degrees F (135 degrees C) gently rotate the cable with the heat shrink tubing in the heat and uniformly shrink the tubing on the cable jacket. Check for a uniform wall thickness as a sign of complete shrinkage.

**NOTE:** Avoid excess heat which may damage the cable's black insulating jacket.

9. Unscrew the battery/transformer housing (Item 5) and set aside.
10. Unsnap and remove the flex relief (Item 6); insert the cable through the flex relief.
11. Remove the steel washer (Item 7) and insert the cable through the washer.
12. Remove the upper cable support (Item 8).

**NOTE:** Refer to Figure 7 for the following steps.

13. Carefully unsolder the old cable wires from the printed circuit board (Item 9).
14. Carefully solder the new cable wires to the printed circuit board following the pictorial in Figure 7. Inspect for loose wires or solder bridges between the solder pads.
15. Assemble the repaired microphone by reversing steps 9 through 12.

#### RE98 INSTRUCTIONS:

1. Disassemble the RE98 microphone to be repaired as follows: (refer to Figure 8)
  - a. Remove the battery from the battery/electronics housing.
  - b. Remove the head capsule (Item 1) by unscrewing it from the electronics housing (Item 3).

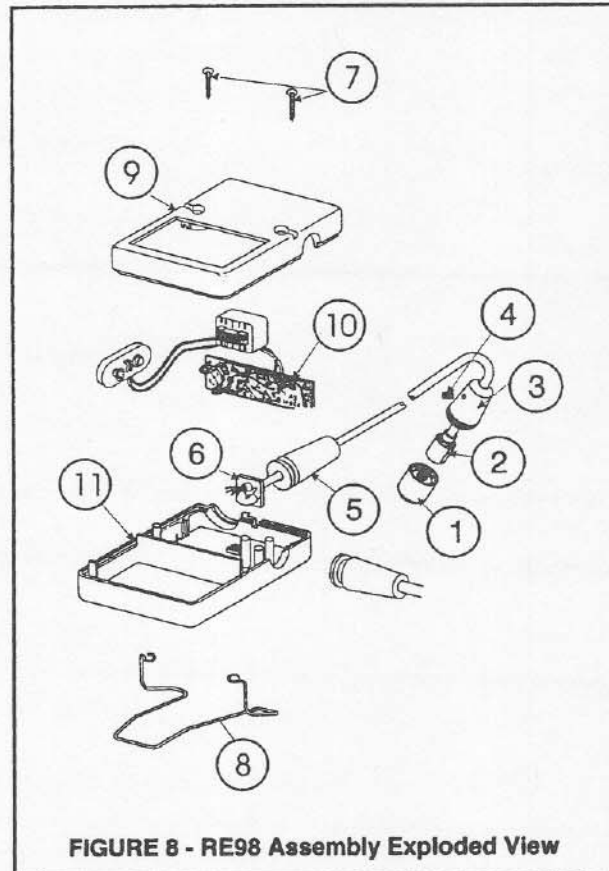

**FIGURE 8 - RE98 Assembly Exploded View**

2. Cut the miniature microphone cable anywhere between Item 3 and Item 5.
3. Loosen the set screw (Item 4) in the electronics housing with the provided .035 hex-key wrench by turning the set screw counterclockwise several turns.
4. Push the cable on Item 2 towards Item 3 and remove Item 2 completely from Item 3. You may discard the old Item 2.
5. Thread the cable end of replacement Item 2 through the hole in Item 3. Pull on the cable until the electronics assembly is seated in Item 3. Tighten the set screw (Item 4) until it is snug and Item 2 is retained in Item 3. Screw the head capsule (Item 1) onto the electronics housing (Item 3).

**NOTE:** Stripping of the delicate inner conductor insulation is best accomplished with wire strippers or with the tip of a hot soldering iron. (Refer to Figure 4).

6. Measure and carefully remove .5 inch (12.7 mm) of the black outer jacket insulation from the end of the cable.

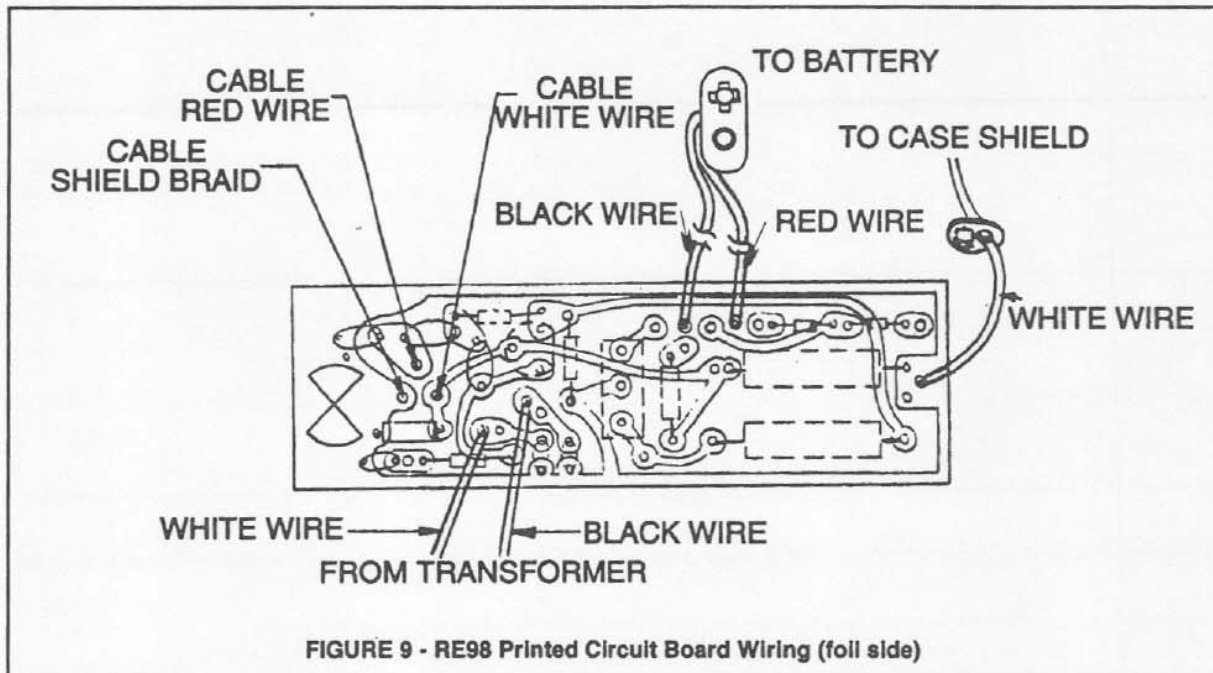
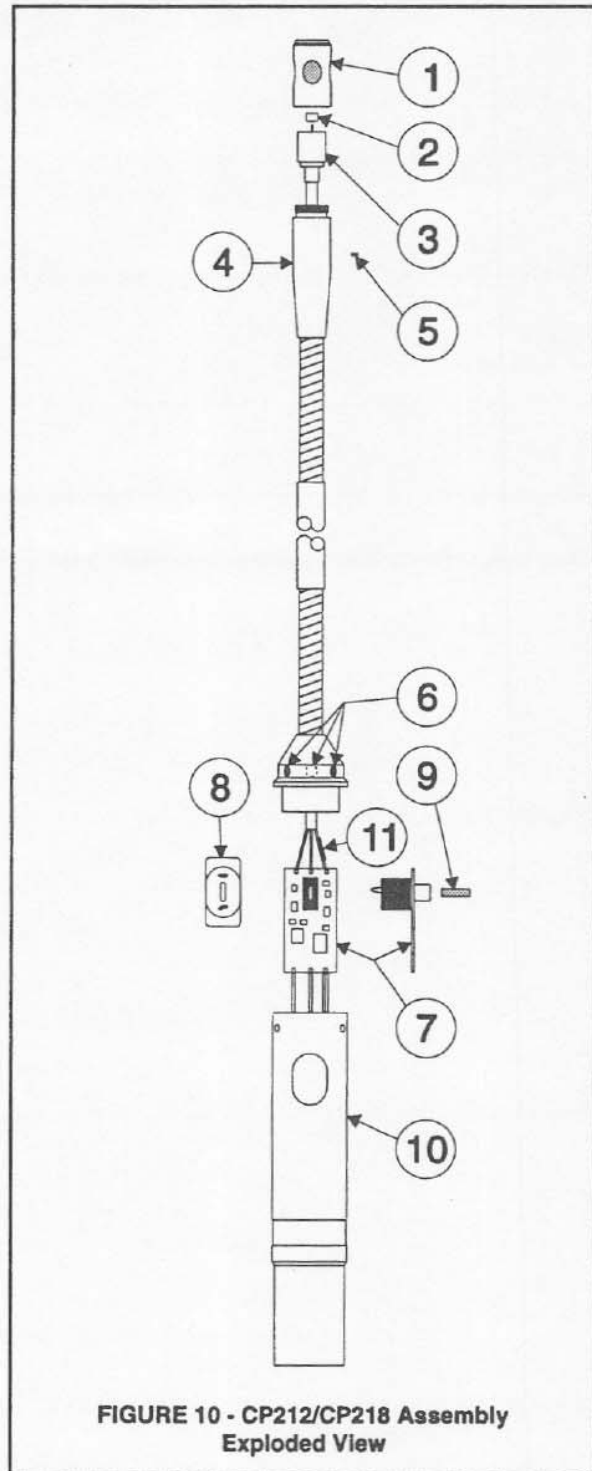

FIGURE 9 - RE98 Printed Circuit Board Wiring (foil side)

7. Carefully remove the white and red wires from the inside of the braided shield. This can be done by bending the braid at the jacket and with tweezers or needle nosed pliers by gently separating the braid at the bend then pull and remove the wires. Remove and cut off all cotton threads encased in the shield braid.
8. Measure and remove .25 inch (6.3 mm) of insulation from the red and white wire. Temporarily set aside this assembly.
9. Remove the two cross-recessed head screws (Item 7) from the back case (Item 9).
10. Remove the metal wire belt clip (Item 8) then lift off the back cover of the battery/electronics housing (Item 9).
11. Remove the microphone cable flex relief (Item 5).
12. Gently remove the printed circuit board from the microphone case. Rotate the board so that the foil side is exposed. Unsolder the three microphone cable wires from the printed circuit board (Item 10).
13. Route the new microphone cable through the flex relief (Item 5) then the strain relief (Item 6); use the old cable routing as the reference.
14. Solder the new cable wires to the printed circuit board (refer to Figure 9). Inspect the assembly for loose wires or solder bridges between the solder pads.
15. Reverse steps 9 through 12 to reassemble the repaired microphone.

**CP212 AND CP218 INSTRUCTIONS:**

1. Disassemble the CP212/CP218 microphone to be repaired as follows: (refer to Figure 10)
  - a. Remove the head capsule (Item 1) by unscrewing it from the gooseneck electronics housing (Item 4).
  - b. Gently remove the electrical contact pill (Item 2) from the electronics and cable assembly (Item 3) and set aside.
2. Loosen the set screw (Item 9) in the back of the electronics/transformer housing with the provided .050 hex-key wrench by turning the set screw clockwise until snug. Do not over tighten.
3. Loosen the three set screws (Items 6) located at the top of the electronics/transformer housing with the provided .050 hex-key wrench by turning the set screws (Items 6) clockwise until stopped. Do not tighten.
4. Gently press in the switch cover (Item 8) then slowly pull away the gooseneck assembly until the printed circuit board (Item 7) is fully uncovered. NOTE: Some models of the CP212/CP218 have the switch cover (Item 8) glued to the switch on the printed circuit board (Item 7). If the switch cover is glued to the switch, then proceed with step 5. If the switch cover is not glued to the switch, then remove the switch cover from the printed circuit board and, upon reassembly, consult Figure 10 for the proper cover orientation.
5. Unsolder the three wires from the electronics and cable assembly (Item 3) from the printed circuit board (Item 7). Separate the gooseneck assembly from the electronics/transformer housing (Item 10).
6. Loosen the set screw (Item 5) in the gooseneck electronics housing (Item 4) with the provided .035 hex-key wrench by turning the set screw counterclockwise several turns.
7. Cut off the exposed cable wires of Item 3, then with needle nosed pliers, grasp the wire contact of Item 3 at the head of the gooseneck assembly and gently pull and twist completely removing Item 3 from Item 4.



**FIGURE 10 - CP212/CP218 Assembly  
Exploded View**



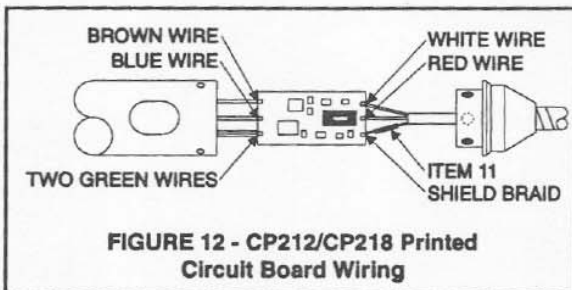
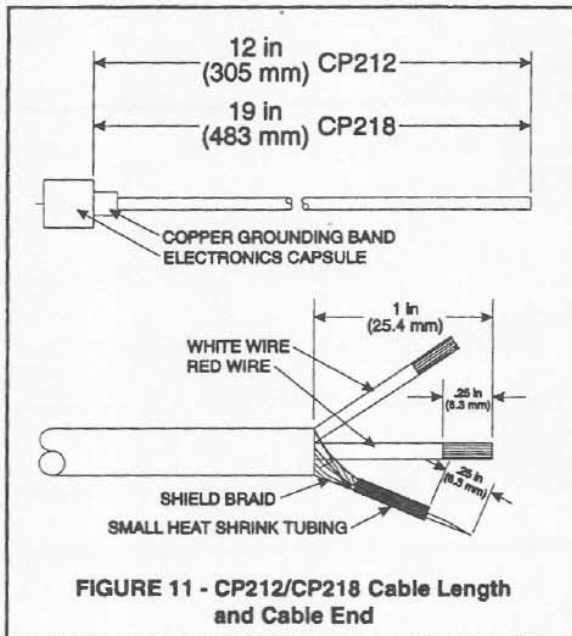

**NOTE:** Refer to Figure 11 for the following steps.

**NOTE:** Stripping of the delicate inner conductor insulation is best accomplished with wire strippers or with the tip of a hot soldering iron.

8. Measure from the junction of the base of the electronics capsule and the copper grounding band 12 inches (305 mm) for the CP212 or 19 inches (483 mm) for the CP218 of the black jacketed cable and cut.
9. For both models, measure and carefully remove 1 inch (25.4 mm) of the black outer jacket insulation from the end of the cable.
10. Carefully remove the white and red wires from the inside of the braided shield. This can be done by bending the braid at the jacket and with tweezers or needle nosed pliers by gently separating the braid at the bend then pull and remove the wires. Remove and cut off all cotton threads encased in the shield braid.

11. Measure and remove .25 inch (6.3 mm) of insulation from the red and white wires.
12. Tin the ends of the white and red wires and .25 inch (6.3 mm) of the end of the shield braid.
13. Thread the cable end of the replacement electronics and cable assembly (Item 3) through the hole in the gooseneck assembly (Item 4). Gently push and rotate the cable clockwise. Push on the electronics capsule of Item 3 until the assembly is seated in the gooseneck (Item 4). Tighten set screw (Item 5) until snug and Item 3 is retained in Item 4.
14. Insert the shield braid into the provided small (.63 inch (16 mm) long) piece of black heat shrink tubing. Position the end of the tubing .25 inch (6.3 mm) from the tinned end of the shield braid. Using a heat gun set for 275 degrees F (135 degrees C) gently rotate the cable with the heat shrink tubing in the heat and uniformly shrink the tubing on the shield.

**NOTE:** Avoid excess heat which may damage the cable's black insulating jacket or the red and white wires. If a heat gun is not available, the hot tip of a soldering iron can substitute for a heat gun but care must be taken not to melt the shrink tubing, the cable jacket, or the red and white wire insulation. Check for a uniform wall thickness as a sign of complete shrinkage.

15. Place the electrical contact pill (Item 2) on the contact pin of Item 3. Screw the head capsule (Item 1) onto the gooseneck assembly (Item 4).

**NOTE:** Refer to Figure 12 for the following steps.

16. Carefully solder the new cable wires to the printed circuit board following the pictorial in Figure 12. Inspect for loose wires or solder bridges between the solder pads.
17. Place the switch cover (Item 8) on the switch on the printed circuit board (Item 7). Note: See Figure 10 for correct orientation. Carefully insert this assembly into the electronic/transformer housing (Item 10). Slip the switch cover into the opening.
18. Insert the provided .050 hex-key wrench into the hole opposite the switch cover and capture the set screw on the printed circuit board. Slowly turn the set screw counterclockwise until snug (about five turns). Do not tighten.

19. Insert the gooseneck assembly into the electronics/transformer housing (Item 10). Rotate the gooseneck until the three set screws are aligned with the three openings in Item 10 and the gooseneck capture set screw is oriented opposite of the switch cover.
20. Tighten the three set screws with the provided .050 Hex-Key wrench by turning the set screws counterclockwise until tight.

#### WIRELESS MICROPHONE APPLICATIONS:

The miniature microphone cable used on the CO90E, CO100E, and the CS200E utilizes two wires surrounded by a braided shield. By using two wires and a shield in the microphone cable instead of the usual one wire and a shield, both sides of the FET preamplifier are accessible. By accessing both sides of the FET preamplifier, the CO90E, CO100E, and CS200E may be powered from either a positive or negative power source with respect to ground. This provides the user with greater flexibility when connecting the CO90E, CO100E, or the CS200E with wireless microphone transmitters. See Figure 13 on the instruction sheet for wiring details.

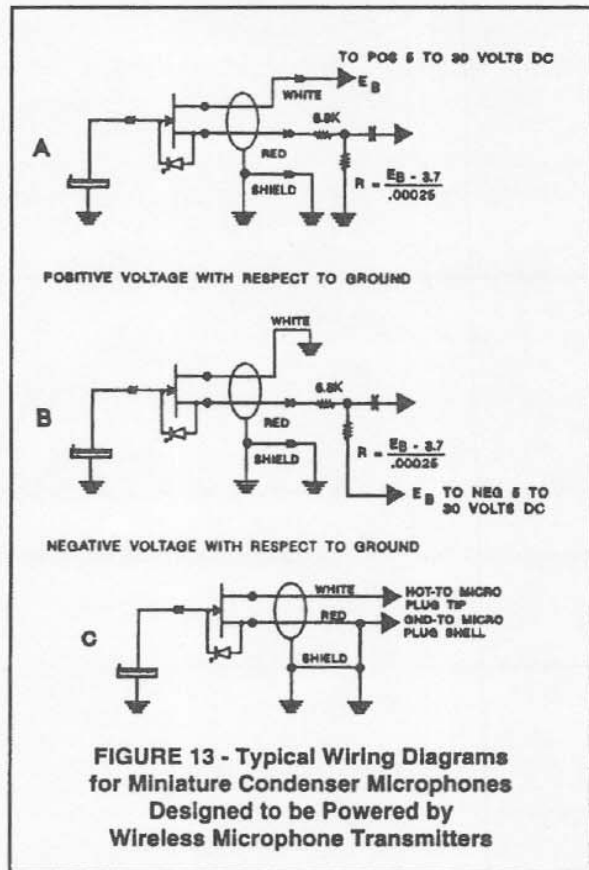

**WARRANTY:**

Electro-Voice products are guaranteed against malfunction due to defects in materials or workmanship for a specified period, as noted in the individual product-line statement(s) below, or in the individual product data sheet or owner's manual, beginning with the date of original purchase. If such malfunction occurs during the specified period, the product will be repaired or replaced (at our option) without charge. The product will be returned to the customer prepaid.

**Exclusions and Limitations:** The Limited Warranty does not apply to: (a) exterior finish or appearance; (b) certain specific items described in the individual product-line statement(s) below, or in the individual product data sheet or owner's manual; (c) malfunction resulting from use or operation of the product other than as specified in the product data sheet or owner's manual; (d) malfunction resulting from misuse or abuse of the product; or (e) malfunction occurring at any time after repairs have been made to the product by anyone other than Electro-Voice or any of its authorized service representatives. **Obtaining Warranty Service:** To obtain warranty service, a customer must deliver the product, prepaid, to Electro-Voice or any of its authorized service representatives together with proof of purchase of the product in the form of a bill of sale or receipted invoice. A list of authorized service representatives is available from Electro-Voice at 600 Cecil Street, Buchanan, MI 49107 (616/695-6831 or 800/234-

6831) and/or Electro-Voice West, at 8234 Doe Avenue, Visalia, CA 93291 (209/651-7777 or 800/825-1242). **Incidental and Consequential Damages Excluded:** Product repair or replacement and return to the customer are the only remedies provided to the customer. Electro-Voice shall not be liable for any incidental or consequential damages including, without limitation, injury to persons or property or loss of use. Some states do not allow the exclusion or limitation of incidental or consequential damages so the above limitation or exclusion may not apply to you. **Other Rights:** This warranty gives you specific legal rights, and you may also have other rights which vary from state to state.

**Electro-Voice Accessories** are guaranteed against malfunction due to defects in materials or workmanship for a period of one (1) year from the date of original purchase. Additional details are included in the Uniform Limited Warranty statement.

Service and repair address for this product: Electro-Voice, Inc., 600 Cecil Street, Buchanan, Michigan 49107 (616/695-6831 or 800/234-6831) or Electro-Voice West, 8234 Doe Avenue, Visalia, CA 93291 (phone: 209-651-7777 or FAX: 209-651-0164).

Specifications subject to change without notice.